



# Oil heating system service plans



Choose the plan  
that's best for  
you and your home.



**Griffith Energy Services has 125 years of experience providing superior home comfort services to customers throughout MD, DE, Northern VA, Washington, DC and the Eastern Panhandle of WV.**

Our insured and certified technicians, with years of experience and expertise servicing and repairing oil heating systems from all major brands, always arrive fully prepared and are trained to ensure that any job is done right on the first visit.

We have two oil heating system service plans to choose from, each created to provide you with year-round peace of mind:

**Depend on Griffith Energy to keep your heating system running all year round.**

Delivering expert service and repairs 24/7, in any weather.

### **Value plan**

Extensive coverage for the budget-minded homeowner.

### **Premier plan**

Comprehensive coverage.

Both plans include:

- **Quality repairs** by experienced technicians
- **Convenient service hours**
- **Periodic tune-ups** to help save you money
- **15% discounts** on non-covered repairs
- **Customer service** team ready to take your call 24/7

See centerfold for a detailed comparison →

## How your oil-fired heating system works.

When your thermostat senses that room temperature has fallen below the heat setting, it sends a signal to your system to provide heat.

The oil burner is engaged and heating oil travels from the tank to the burner by way of a pump, where it becomes a fine mist mixed with air. This fuel/air mixture is then injected into the burner where it is ignited in the combustion chamber.

The way heat then gets distributed throughout your home is based on the type of system it is — hydronic or warm air.



### Hydronic system

In a hydronic or water-based system, water is heated in either a cast iron or steel boiler before it is dispersed throughout your home. There are two main types:

- **Hot water system** – the heated water is circulated through radiators or baseboards
- **Steam system** – water turns to steam and rises through pipes to radiators

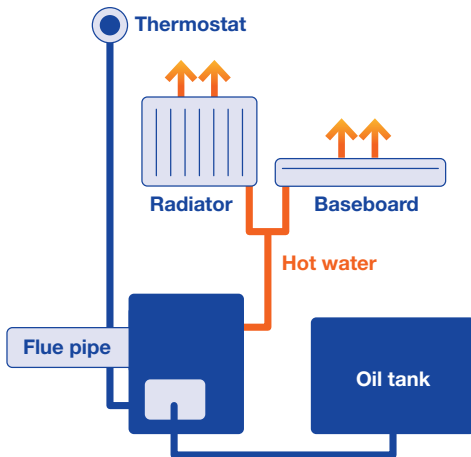

### Warm air system

In a warm air system, your furnace heats air and a blower sends the heated air through ducts and out of vents in your floors or walls.

The air gets drawn back to the furnace through return ducts and the cycle repeats.

Emissions from the combustion of fuel and air exit the system through a flue pipe that runs out of your home through the chimney.

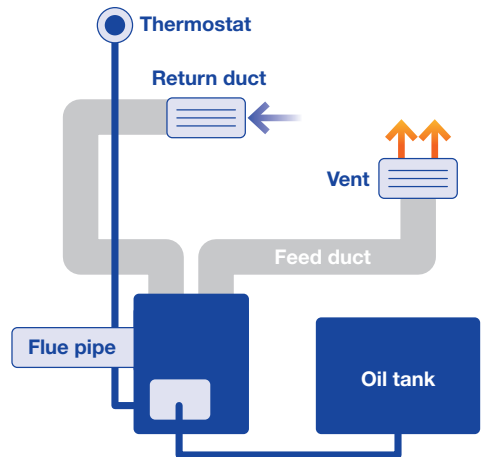

Compare the plans and select the coverage you like best.

Value Plan  
Premier Plan

**Fuel and combustion**

1	Air tube	●	●
1	Burner coupling	●	●
2	Burner fan	●	●
2	Burner motor	●	●
3	Cad cell eye	●	●
3	Cad cell relay	●	●
4	Combustion chamber (wet-based, max 2.5 GPH)		●
5	Delayed oil valve	●	●
6	Draft regulator (up to 9" diameter)	●	●
1	Electrodes	●	●
7	Emergency switch	●	●
1	End cone	●	●
8	Firomatic valve	●	●
9	Fuel pump	●	●
9	Fuel pump gasket	●	●
9	Fuel pump strainer	●	●
10	Flue pipe (max 9" diameter)	●	●
11	Igniters	●	●
11	Ignition transformer	●	●
1	Nozzle	●	●
1	Nozzle adapter	●	●
1	Nozzle line	●	●
	Oil check valve	●	●

12	Oil filter cartridge	●	●
12	Oil filter complete	●	●
	Oil safety valve	●	●
1	Porcelains	●	●
	Primary control	●	●
14	Thermostat standard	●	●
15	Thermostat clock type (\$50 credit)	●	●

**Warm air**

16	Blower complete (up to 3/4 HP)	●	●
17	Blower motor (up to 3/4 HP)	●	●
18	Fan and limit control	●	●
18	Fan control	●	●

**Hot water and steam components**

	Air scoop		●
19	Aquastat (auto type only)		●
19	Aquastat well		●
	Automatic air vent (boiler room only)		●
	Balancing valve		●
20	Boiler drain valve		●
	Boiler relief valve (up to 1" diameter)		●
21	Circulator complete (kitchen zone up to 1/12 HP)		●

Value Plan  
Premier Plan

21	Circulator components (kitchen zone up to 1/12 HP)		●
	Circulator relay (kitchen zone up to 1/12 HP)		●
	Domestic relief valve		●
	Dual valve		●
	Expansion tank (max 24 gallons)		●
	Expansion tank valve		●
	Extrol tank (max # 60)		●
	Feed valve		●
	Feed valve washer		●
	Flow check valve		●
22	Gauge glass and washers	●	●
	Limit control		●
	Low voltage transformer		●
	Manual feed valve		●
	Pop safety valve (up to 1" diameter)		●
	Pressure gauge		●
	Pressuretrol (auto type only)		●
13	Pressure/temperature gauge		●
	Zone valve complete (kitchen zone up to 1" diameter)		●
	Zone valve component (kitchen zone up to 1" diameter)		●

Value Plan  
Premier Plan

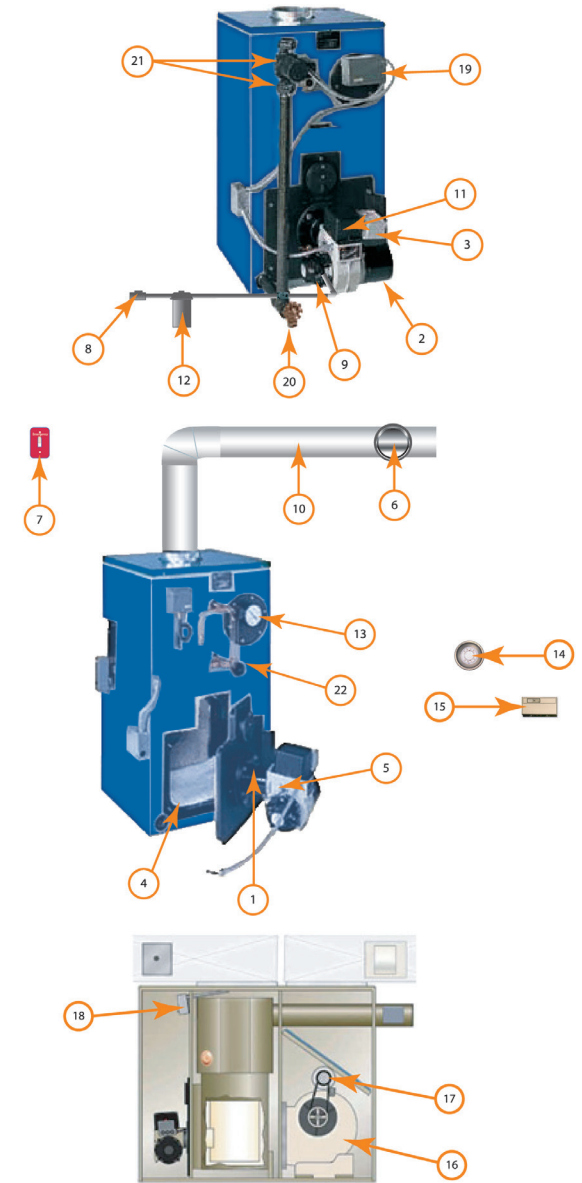

Service requested to start prior to 8:00am or after 5:00pm, on federal holidays (days when the post office is closed) or weekends, is subject to our after hours diagnostic fee, unless you have purchased the 24/365 enhancement. The service plans described in this brochure are subject to Griffith Energy's terms and conditions of service which are provided and incorporated by reference into this brochure.

## Still need more coverage?

We have other enhancements and agreements that are available at an additional cost to your existing plan and these are priced separately. They allow you to extend your coverage with more comprehensive protection and help you prepare for unexpected repair costs by allowing you to customize your protection to suit your needs. You must currently have a Griffith Energy Value or Premier Service Plan to add any enhancement coverage.

---

## Optional enhancements

### 24 hours-a-day/365 days-a-year service

This enhancement extends your primary coverage by giving you access to Griffith Energy service 24 hours a day, 365 days a year. It waives our after hours diagnostic fee.

### Direct and indirect water heater repair and part replacement\*

This enhancement covers repairs and replacement of the parts listed below:

- Air tube
- Aquastat (auto type only)
- Burner coupling
- Burner fan
- Burner motor
- Cad cell complete
- Circulator (bronze type, up to 1/16 HP)
- Delayed oil valve
- Draft regulator (up to 9" diameter)
- Drain valve
- Drip tube
- Electrodes
- Electrode wire and clips
- Emergency switch
- End cone
- Fiomatic valve
- Flue pipe (up to 9" diameter)
- Fuel pump
- Fuel pump gasket
- Fuel pump strainer
- Igniters
- Ignition transformer
- Nozzle
- Nozzle adapter
- Nozzle line
- Oil check valve
- Oil filter cartridge
- Oil filter complete
- Oil safety valve
- Porcelains
- Preference relay
- Primary control
- Relief valve

\*Covers residential, oil-fired water heaters up to a maximum firing rate of 1.25 gallons per hour. **Excludes coverage of the water heater tank,** recirculation lines and components, and anode rods. Service requested to start prior to 8:00am or after 5:00pm, on federal holidays (days when the post office is closed), or weekends, is subject to our standard diagnostic fee, unless you have purchased the 24/365 enhancement. Repair and/or replacement must be performed by Griffith Energy.

### Limited boiler and furnace replacement\*\*

This coverage provides an allowance of \$1,000 toward replacement of your main heating boiler or furnace if a Griffith Energy inspection determines that your existing equipment is not repairable. The new boiler or furnace must be replaced by Griffith Energy. Allowance is payable as a reduction to our normal retail price for the model specified.

\*\*Existing equipment must be inspected by Griffith Energy to qualify.

## Optional Zone Coverage\*\*\*

This enhancement covers repair and replacement of the parts listed below:

- Automatic air vents (boiler room only)
- Circulator complete (up to 1/12 HP)
- Circulator coupling (up to 1/12 HP)
- Circulator flanges and gaskets (up to 1-1/2" diameter)
- Circulator impeller (up to 1/12 HP)
- Circulator motor (up to 1/12 HP)
- Circulator mounts (up to 1/12 HP)
- Circulator relay
- Flow check valve (up to 1-1/2" diameter)
- Isolation valves (up to 1-1/2" diameter)
- Thermostat (standard)
- Thermostat (clock type \$50 credit)
- Zone valve (up to 1" diameter)
- Zone valve motor (up to 1" diameter)

\*\*\*Not available on steam systems and excludes air handlers. Service requested to start prior to 8:00am or after 5:00pm, on federal holidays (days when the post office is closed) or weekends, is subject to our standard diagnostic fee, unless you have purchased the 24/365 enhancement. Repair and/or replacement must be performed by Griffith Energy.

---

## Additional agreements

### CARE® environmental protection

Fortunately, oil leaks don't happen too often, but when they do, they can damage the environment and cost thousands of dollars to clean up. Most homeowners insurance doesn't cover oil leaks. The CARE program is available for above-ground fuel tanks† and provides:

- Up to \$100,000 for clean-up\*\*\*\*
- Clean-up of releases from entire fuel oil system, including piping and lines
- Limited cost share
- Transferable if you sell your home
- Experienced professionals to handle the work

†A separate program is available for underground fuel oil storage tanks. Underground oil tanks require a one-time testing fee in addition to the cost of the program. \*\*\*\*Does not include tank replacement.

### Oil tank agreement

In the event of an oil tank failure, this agreement gives you an allowance of \$750 toward a replacement tank. Your allowance is payable as a reduction to our normal retail price for the model specified. Replacement or repair must be done by Griffith Energy. Additionally, this coverage includes:

- Exposed fill and vent lines (up to 15 feet from the tank)
- Exposed oil lines (up to 15 feet from the tank), tank legs, vent alarm and tank valve



Contact us today for more information and special offers.

**888.474.3391**

[griffithenergyservices.com](http://griffithenergyservices.com)



Heating Oil | Propane | HVAC Services  
Heating Equipment | Water Heaters  
Cooling | Indoor Air Quality

The service plans described in this brochure are subject to Griffith Energy's terms and conditions of service which are provided and incorporated by reference into this brochure. Not all products and services are available in all areas. Contact your Griffith Energy Services representative for complete details. MD Lic. HVAC-R 01-16999. ©2025 Griffith Energy Services. GR\_25042